

アルミ押出し型材集

2020年9月版



日本ウォール建材株式会社

■ 角型アルミルーバー ■

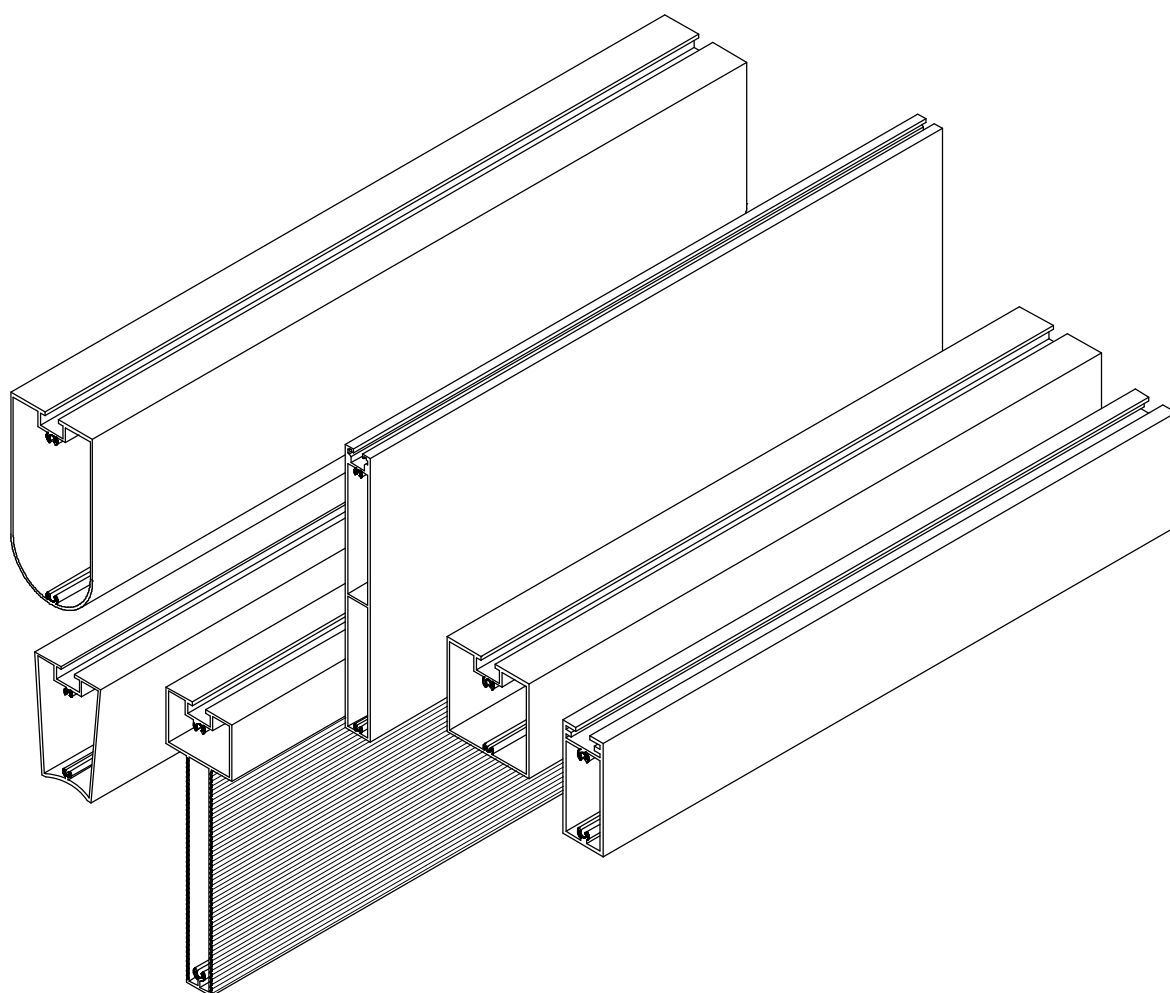

NW-LS1550

使用ボルト	M 6
単位重量	0.627 Kg/m
DIE NO	3SYZ-3707

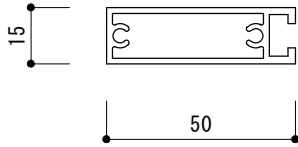
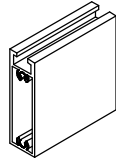

NW-LS1510

使用ボルト	M 6
単位重量	1.032 Kg/m
DIE NO	3SYZ-3631

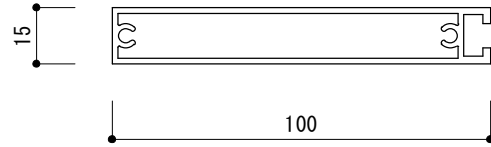
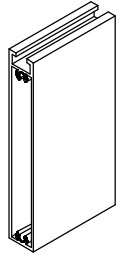

NW-LS2040

使用ボルト	M 8
単位重量	0.685 Kg/m
DIE NO	※

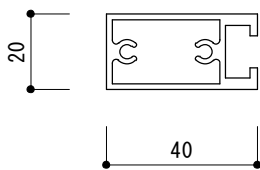
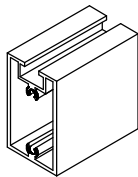

NW-LS2060

使用ボルト	M 8
単位重量	0.807 Kg/m
DIE NO	3SYZ-3061

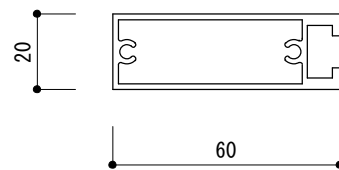
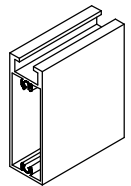

NW-LS2080

使用ボルト	M 8
単位重量	0.969 Kg/m
DIE NO	3SYZ-3062

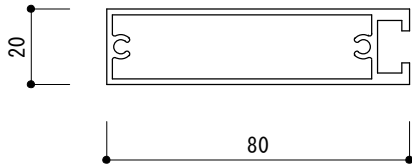
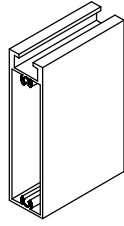

NW-LS2010

使用ボルト	M 8
単位重量	1.131 Kg/m
DIE NO	3SYZ-3063

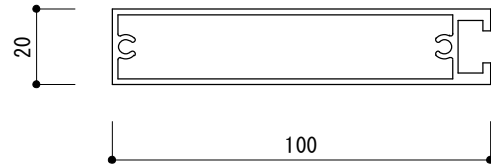
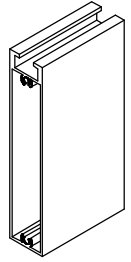

NW-LS2014

使用ボルト	M 8
単位重量	1.52 Kg/m
DIE NO	※

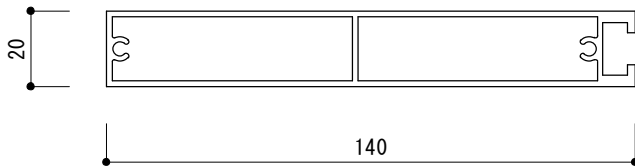
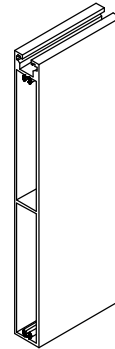

NW-LS2015

使用ボルト	M 8
単位重量	1.61 Kg/m
DIE NO	SYZ-16251

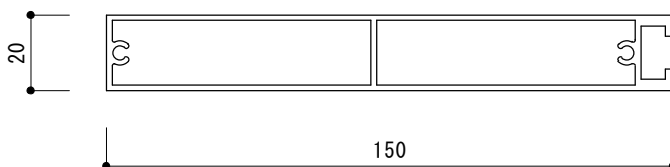
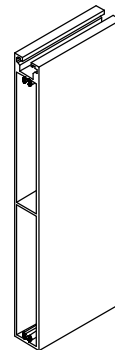

NW-LS2018

使用ボルト	M 8
単位重量	1.85 Kg/m
DIE NO	※

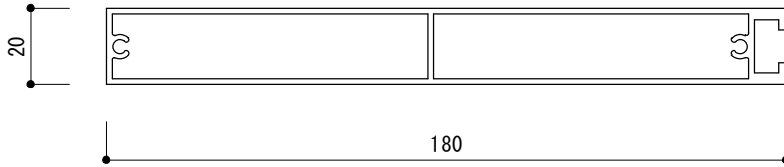
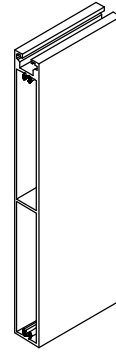

NW-LS2550

使用ボルト	M 8
単位重量	0.807 Kg/m
DIE NO	※

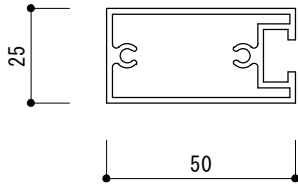
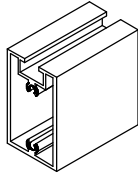

NW-LS2560

使用ボルト	M 8
単位重量	1.076 Kg/m
DIE NO	SYZ-04986

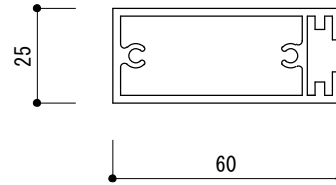
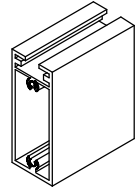

2.0t

NW-LS2580

使用ボルト	M 8
単位重量	0.920 Kg/m
DIE NO	3SYZ-1477

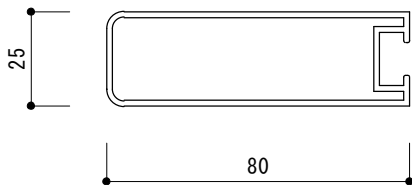
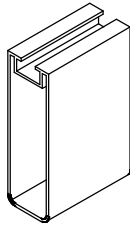

NW-LS2515

使用ボルト	—
単位重量	1.97 Kg/m
	0.17 Kg/m
DIE NO	SYZ-09777(本体)
DIE NO	SYZ-09778(受)

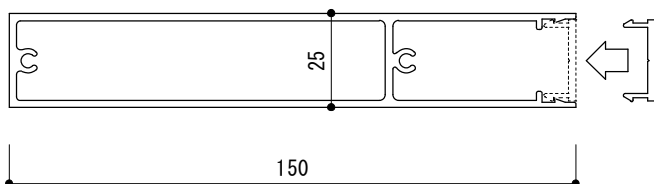
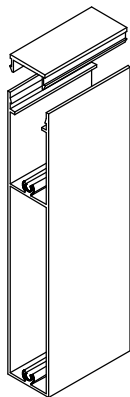

NW-LS3050

使用ボルト	M 8
単位重量	0.761 Kg/m
DIE NO	3SYZ-2778

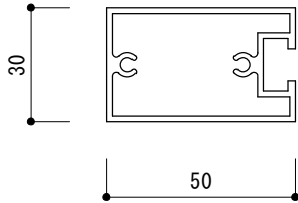
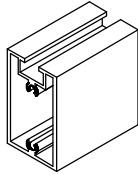

NW-LS3060

使用ボルト	M 8
単位重量	0.901 Kg/m
DIE NO	3SYZ-3065

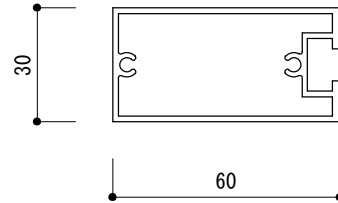
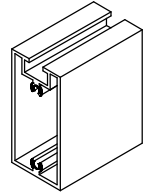

NW-LS3075

使用ボルト	M 6
単位重量	1.016 Kg/m
DIE NO	3SYZ-1402

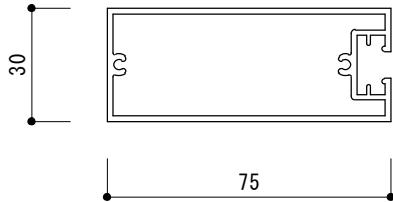
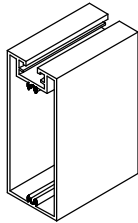

NW-LS3080

使用ボルト	M 8
単位重量	1.092 Kg/m
DIE NO	※

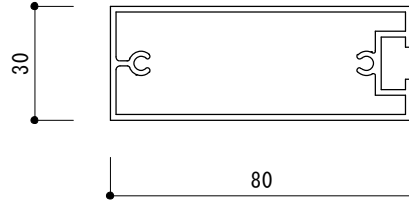
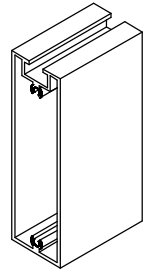

NW-LS3090

使用ボルト	M 8
単位重量	1.173 Kg/m
DIE NO	SYZ-08973

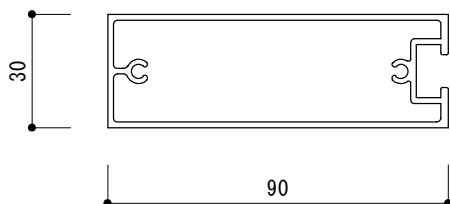
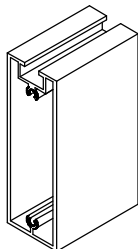

NW-LS3010

使用ボルト	M 8
単位重量	1.225 Kg/m
DIE NO	3SYZ-3066

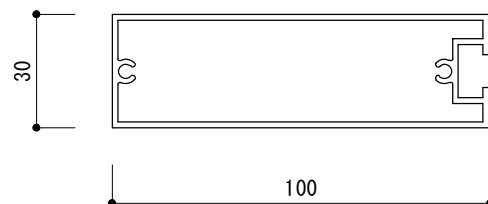
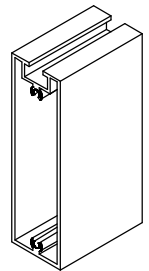

NW-LS3012

使用ボルト	M 8
単位重量	1.434 Kg/m
DIE NO	1805-21-1

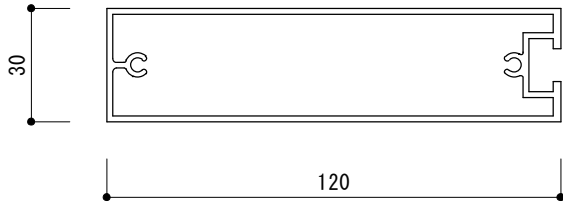
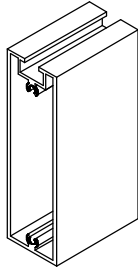

NW-LS3015

使用ボルト	M 8
単位重量	1.741 Kg/m
DIE NO	3SYZ-3067

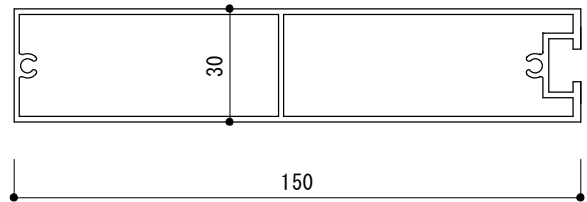
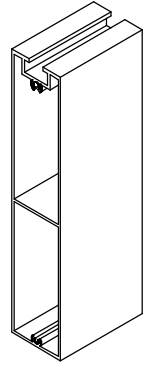

NW-LS3015W

使用ボルト	—
単位重量	1.602 Kg/m
	0.21 Kg/m
DIE NO	SYZ-16634(本体)
DIE NO	SYZ-16633(受)

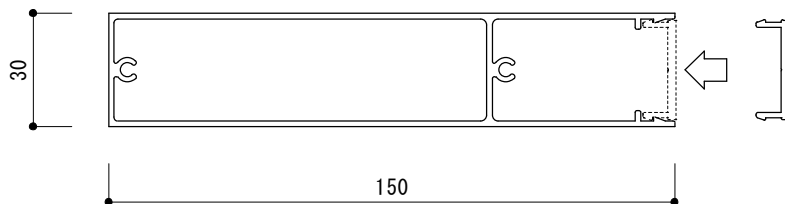
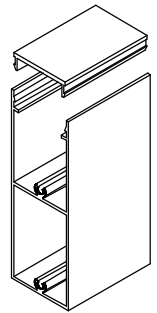

NW-LS3018

使用ボルト	M 8
単位重量	5.02 Kg/m
DIE NO	※

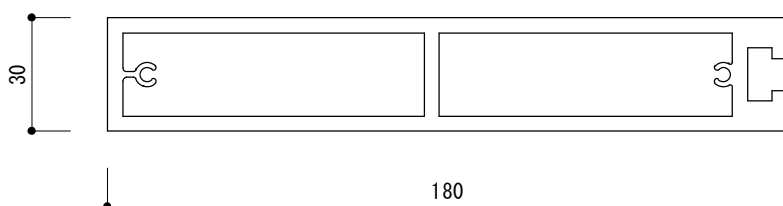
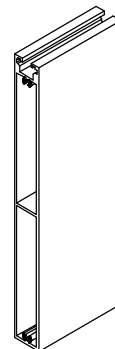

4.0t

NW-LS3570

使用ボルト	M 8
単位重量	1.058 Kg/m
DIE NO	※

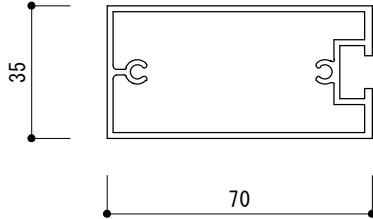
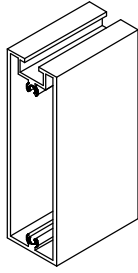

NW-LS3515

使用ボルト	M 8
単位重量	1.831 Kg/m
DIE NO	※

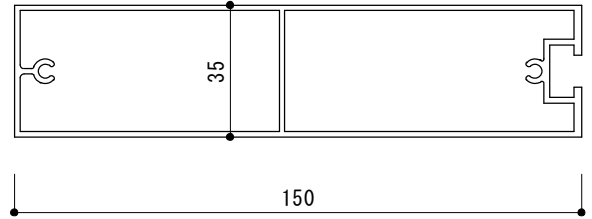
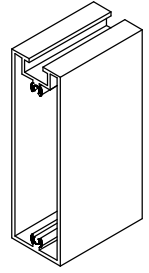

NW-LS4050

使用ボルト	M 8
単位重量	0.943 Kg/m
DIE NO	※

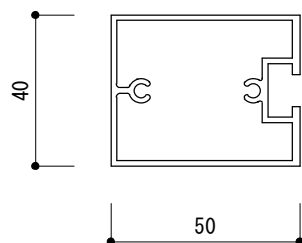
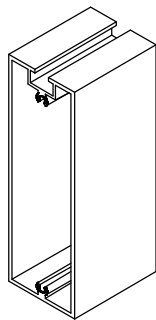

NW-LS4060

使用ボルト	M 8
単位重量	1.02 Kg/m
DIE NO	SYZ-16526

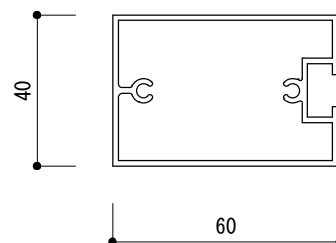
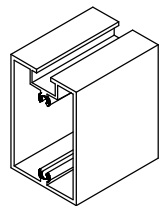

NW-LS4080

使用ボルト	M 8
単位重量	1.187 Kg/m
DIE NO	※

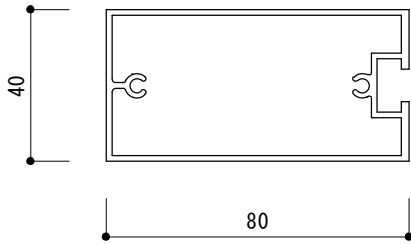
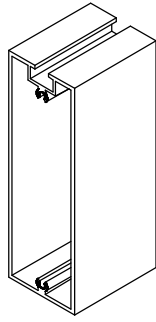

NW-LS4012

使用ボルト	M 8
単位重量	1.513 Kg/m
DIE NO	SYZ-08975

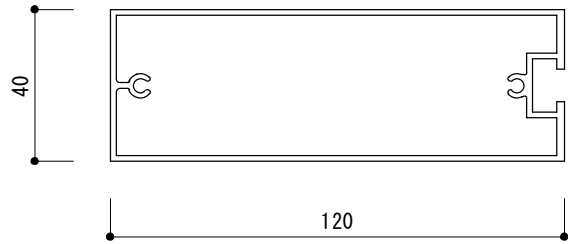
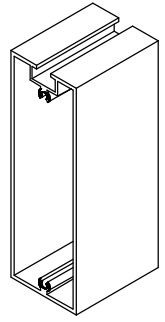

NW-LS4014

使用ボルト	M 8
単位重量	1.83 Kg/m
DIE NO	※

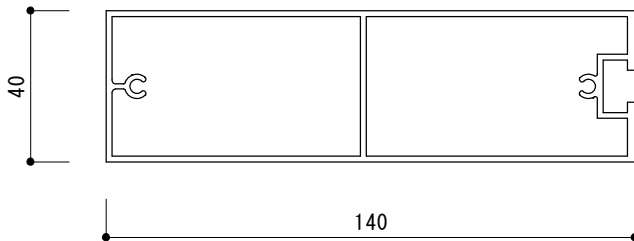
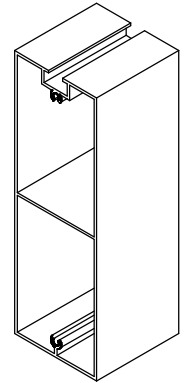

NW-LS4018

使用ボルト	M 8
単位重量	3.396 Kg/m
DIE NO	1805-21-3

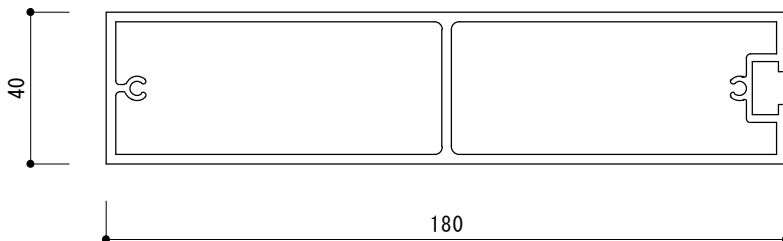
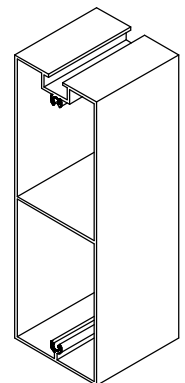

NW-LS5020

使用ボルト	M 8
単位重量	0.816 Kg/m
DIE NO	1805-21-2

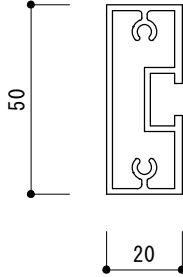
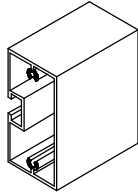

NW-LS5050

使用ボルト	M 8
単位重量	1.009 Kg/m
DIE NO	3SYZ-3064

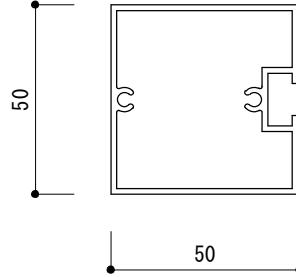
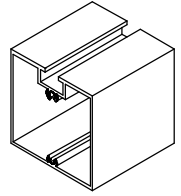

NW-LS5060

使用ボルト	M 8
単位重量	1.006 Kg/m
DIE NO	3SYZ-2780

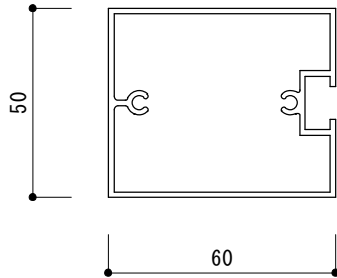
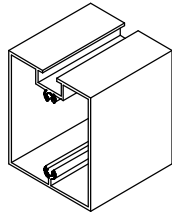

NW-LS5010

使用ボルト	M 8
単位重量	1.431 Kg/m
DIE NO	3SYZ-2777

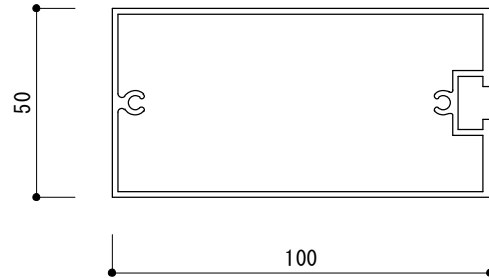
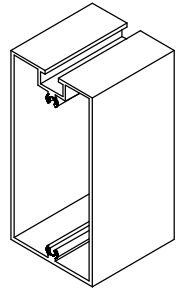

NW-LS5010R

使用ボルト	M 8
単位重量	1.329 Kg/m
DIE NO	3SYZ-3068

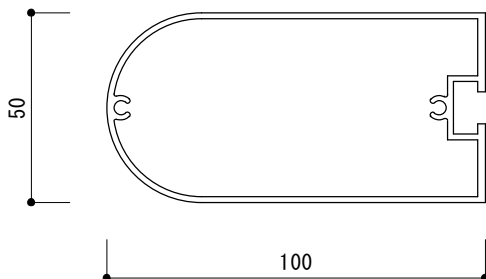
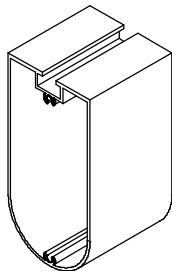

NW-LS5015

使用ボルト	M 8
単位重量	2.05 Kg/m
DIE NO	SYZ-09664

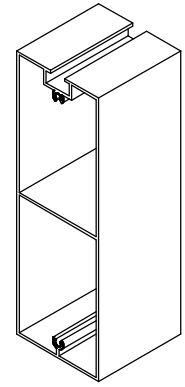
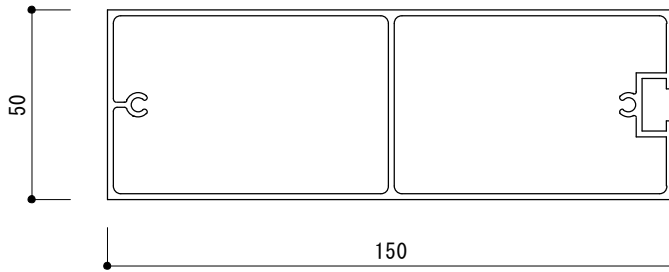

NW-LS5030

使用ボルト	M 12
単位重量	6.493 Kg/m
DIE NO	SYZ-09665

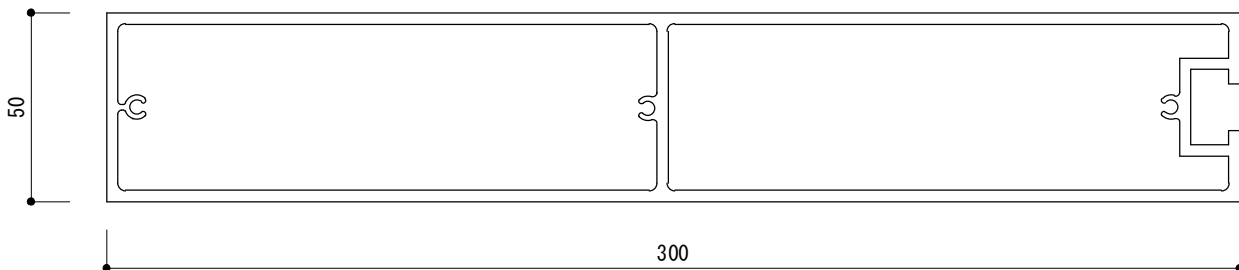
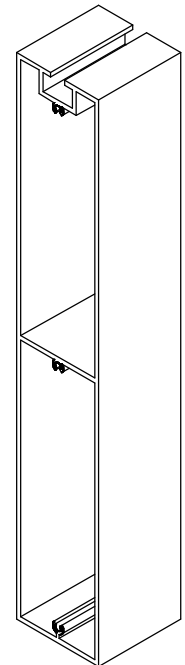

NW-LS6030

使用ボルト	M 8
単位重量	0.902 Kg/m
DIE NO	SYZ-04612

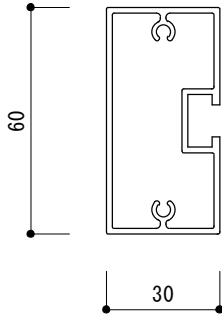
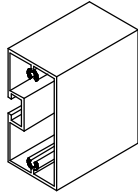

NW-LS6012

使用ボルト	M 8
単位重量	1.692 Kg/m
DIE NO	SYZ-08974

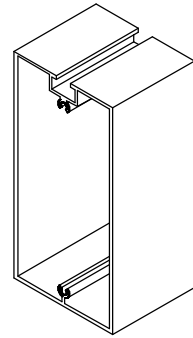

NW-LS5022

使用ボルト	M 8
単位重量	3.61 Kg/m
DIE NO	※

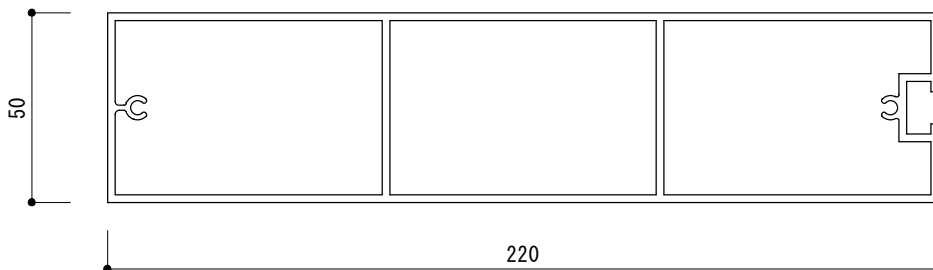
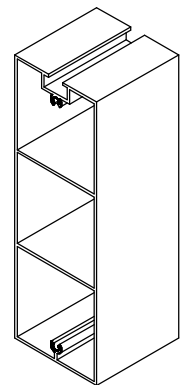

2.0t

NW-LS7575

使用ボルト	M 8
単位重量	1.81 Kg/m
DIE NO	※

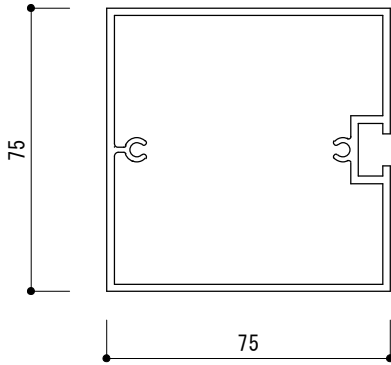
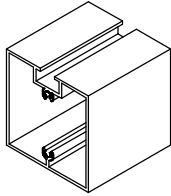

2.0t

NW-LS1050

使用ボルト	M 8
単位重量	1.39 Kg/m
DIE NO	※

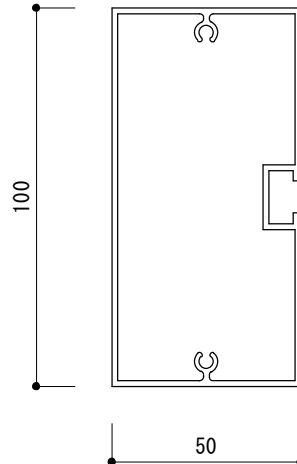
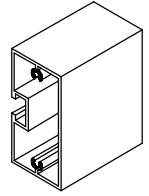

NW-LS3733

使用ボルト	M 1 2
単位重量	6.82 Kg/m
DIE NO	SYZ-15018

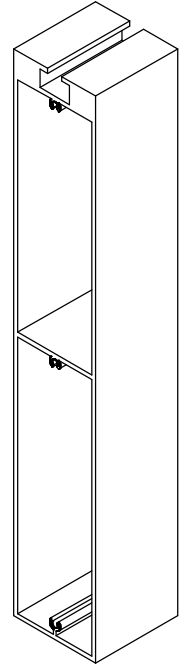
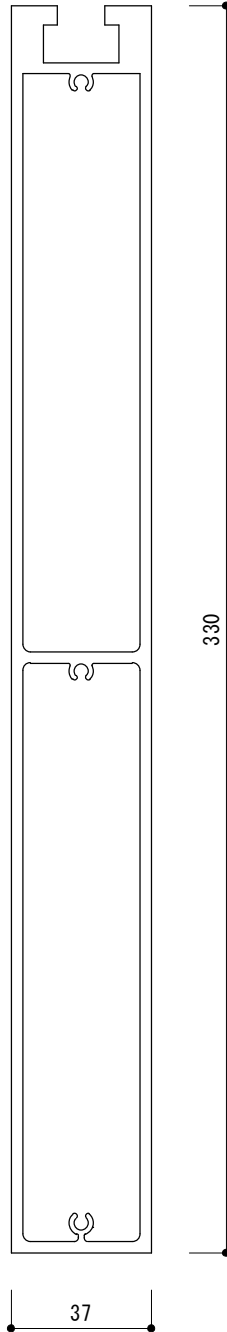

NW-LS6346

使用ボルト	M 1 6
単位重量	13.811 Kg/m
DIE NO	SYZ-15019

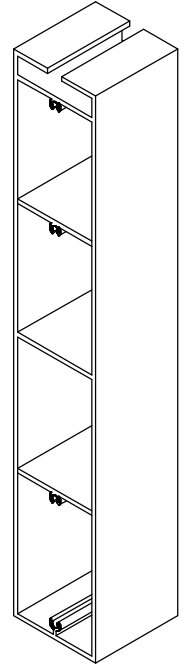
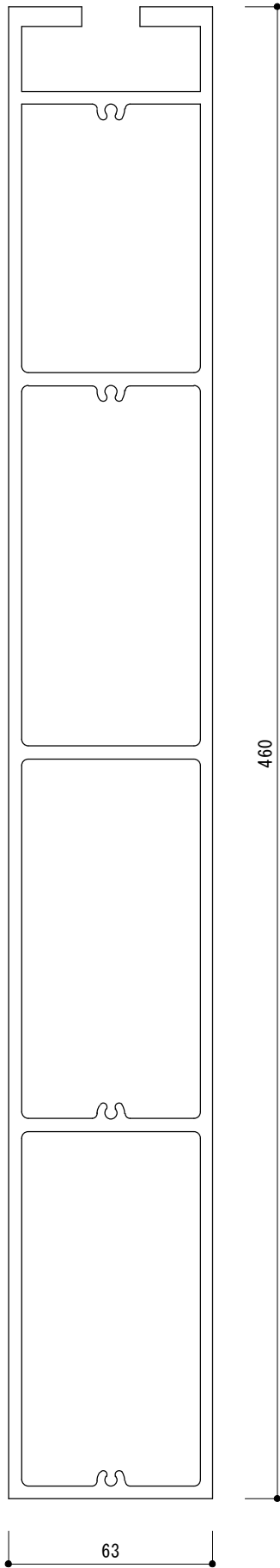

NW-LT5070

使用ボルト	M 8
単位重量	1.101 Kg/m
DIE NO	SYZ-02993

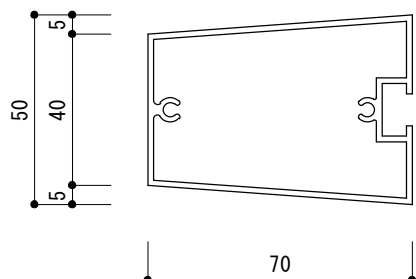
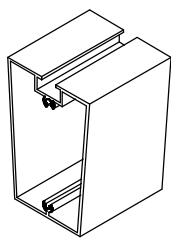

NW-LST0660	
使用ボルト	M 5
単位重量	0.468 Kg/m
DIE NO	SYZ-04734

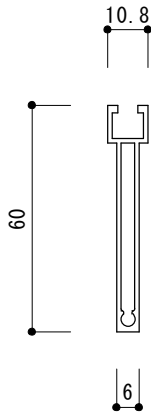
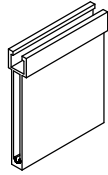

NW-LST0990	
使用ボルト	M 6
単位重量	0.835 Kg/m
DIE NO	SYZ-04793

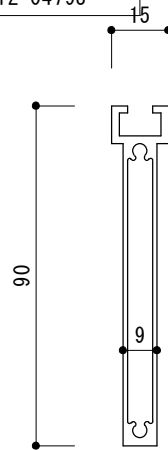
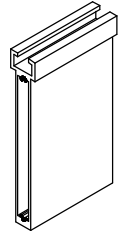

NW-LST1565	
使用ボルト	M 8
単位重量	1.044 Kg/m
DIE NO	3SYZ-3636

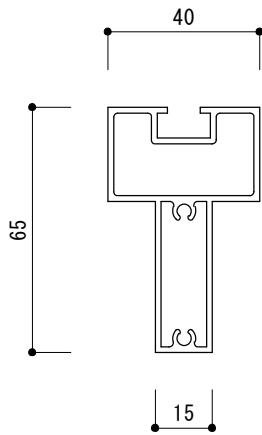
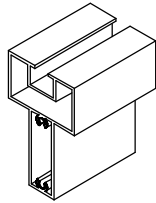

NW-LST1510	
使用ボルト	M 8
単位重量	1.327 Kg/m
DIE NO	3SYZ-1416

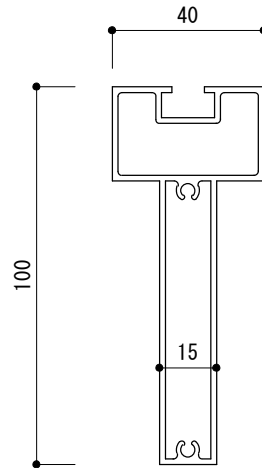
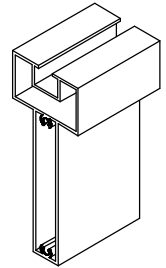

NW-LST1515

使用ボルト	M 8
単位重量	1.740 Kg/m
DIE NO	3SYZ-2779

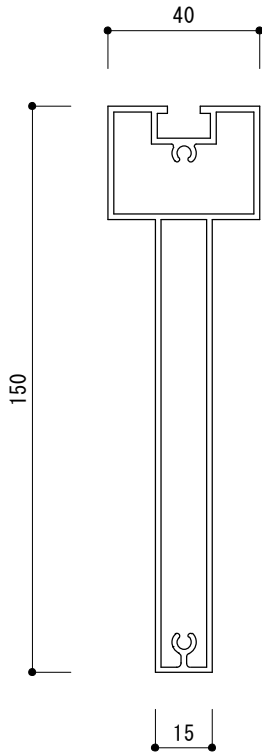
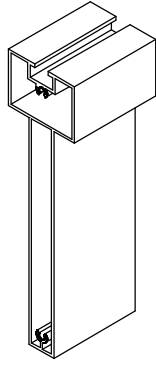

NW-LST1515W

使用ボルト	M 8
単位重量	1.904 Kg/m
DIE NO	3SYZ-3974

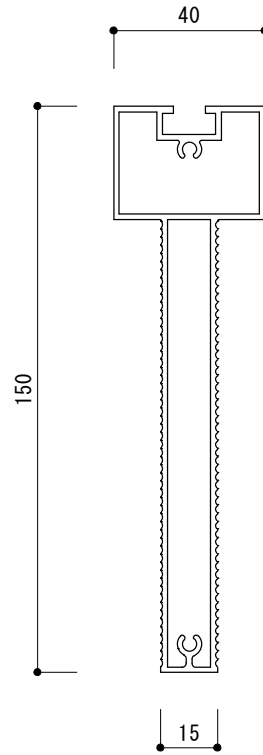
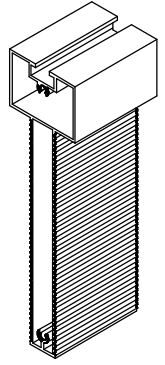

■ ラウンドタイプアルミルーバー ■

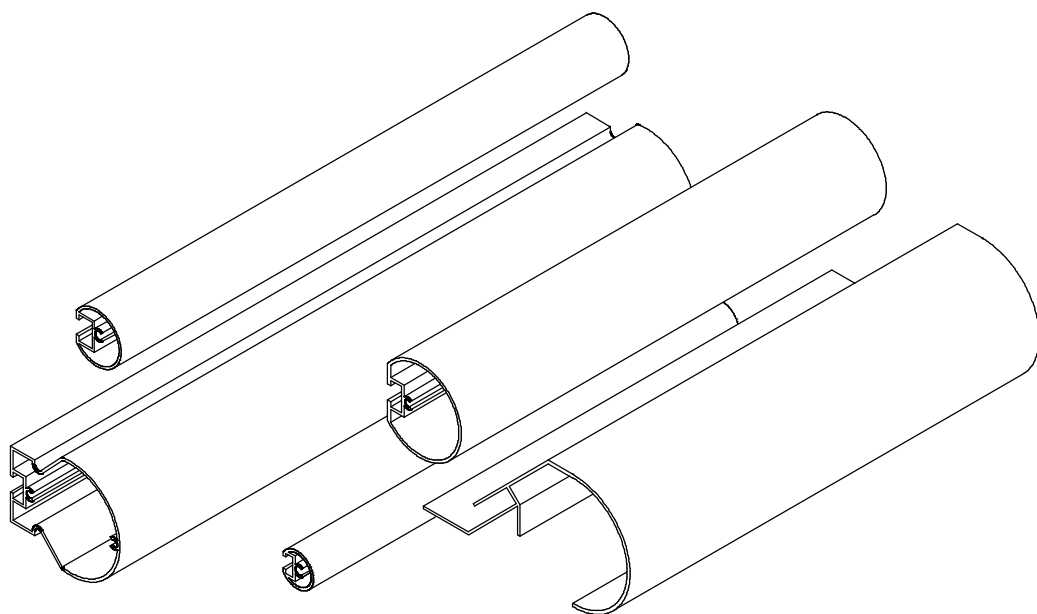

NW-LP2018

使用ボルト	M 6
単位重量	0.334 Kg/m
DIE NO	3SYZ-4104

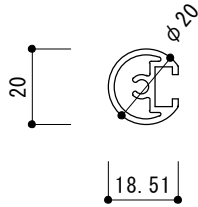
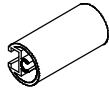

NW-LP3027

使用ボルト	M 8
単位重量	0.457 Kg/m
DIE NO	3SYZ-1187

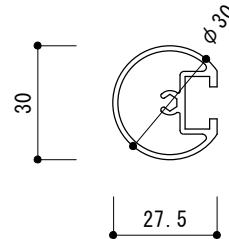
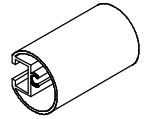

NW-LP5045

使用ボルト	M 8
単位重量	0.808 Kg/m
DIE NO	3SYZ-3071

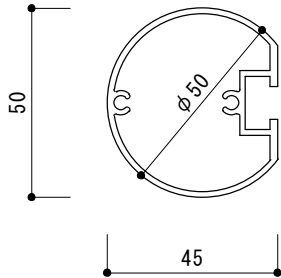
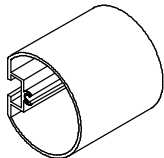

NW-LP6060

使用ボルト	M 8
単位重量	1.012 Kg/m
DIE NO	3SYZ-3708

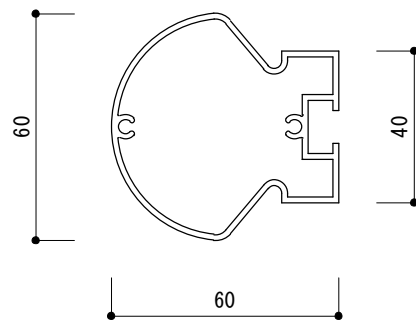
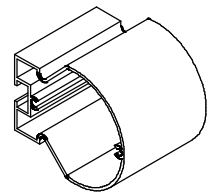

■ フィンタイプアルミルーバー ■

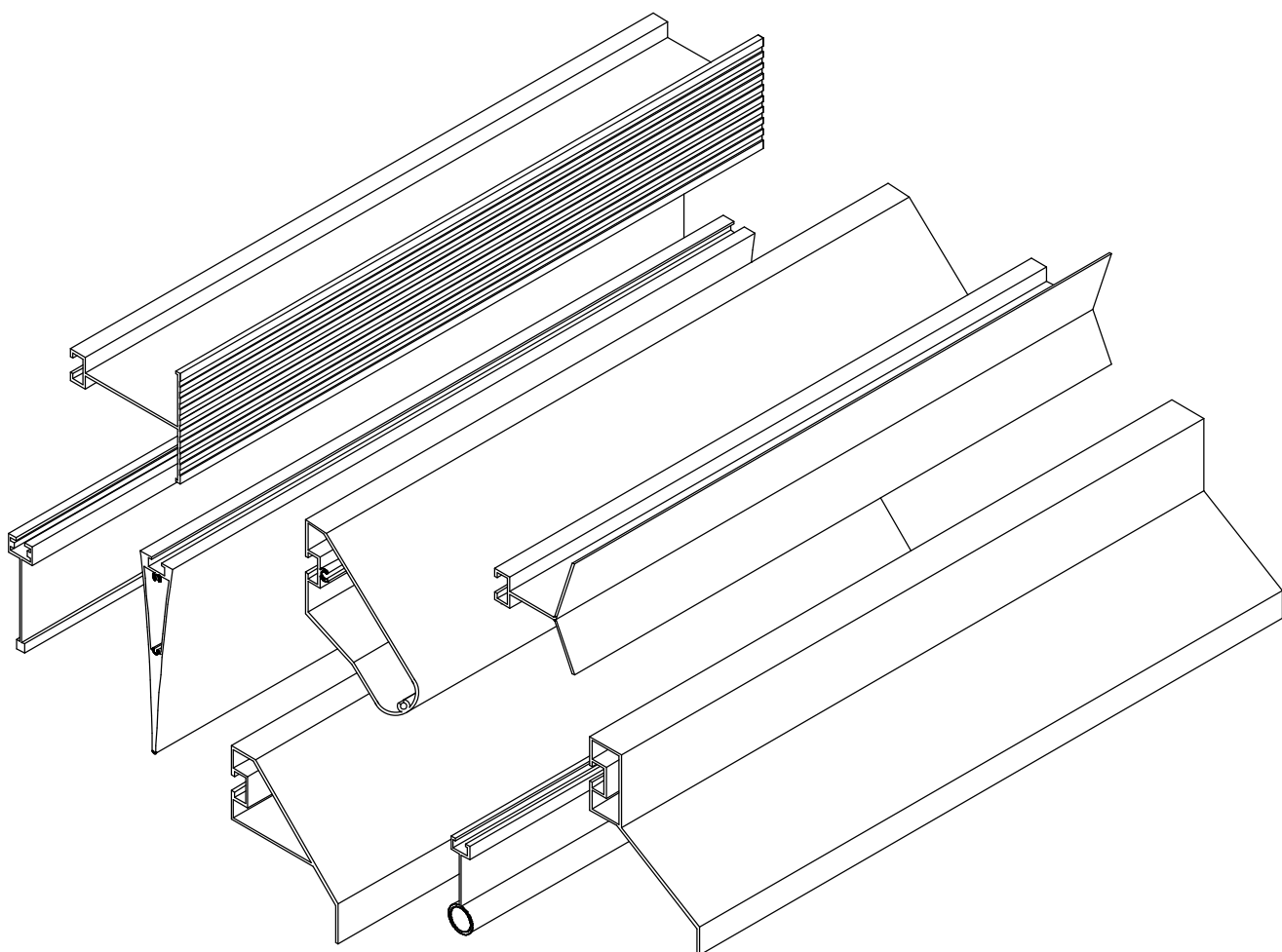

NW-LF2580

使用ボルト	M 8
単位重量	0.74 Kg/m
DIE NO	SYZ-09663

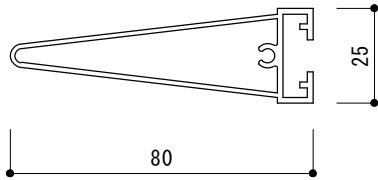
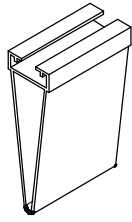

NW-LFR5070

使用ボルト	M 8
単位重量	0.919 Kg/m
DIE NO	3SYZ-3995

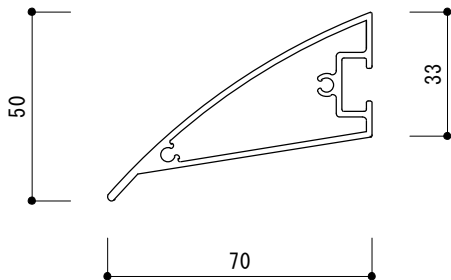
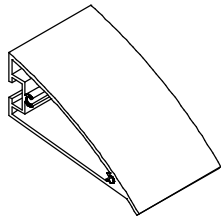

NW-LFR1060

使用ボルト	M 8
単位重量	1.323 Kg/m
DIE NO	3SYZ-0402

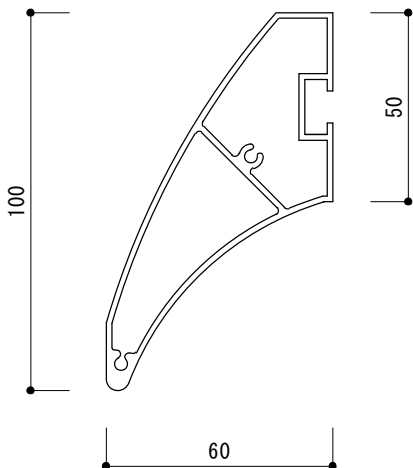
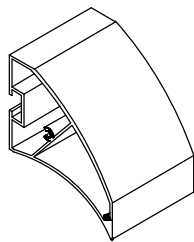

NW-LF1060T1

使用ボルト	M 8
単位重量	1.211 Kg/m
DIE NO	3SYZ-3069

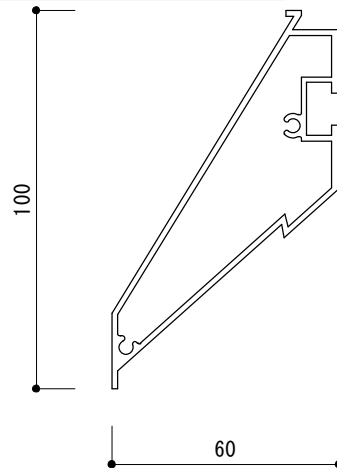
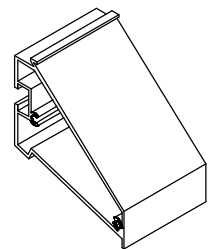

NW-LFR1063

使用ボルト	M 8
単位重量	1.198 Kg/m
DIE NO	3SYZ-1422

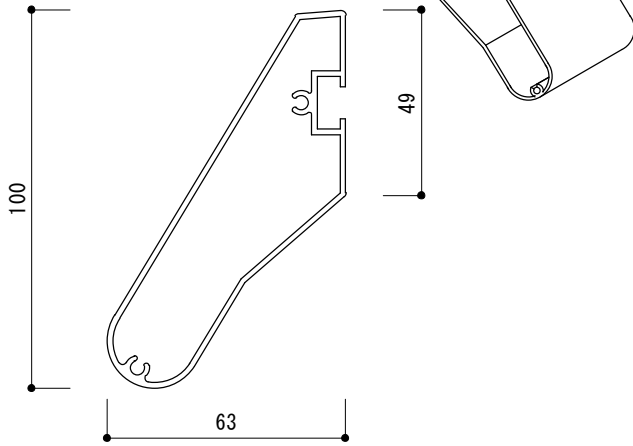

NW-LF8070

使用ボルト	M 8
単位重量	1.047 Kg/m
DIE NO	SYZ-14897

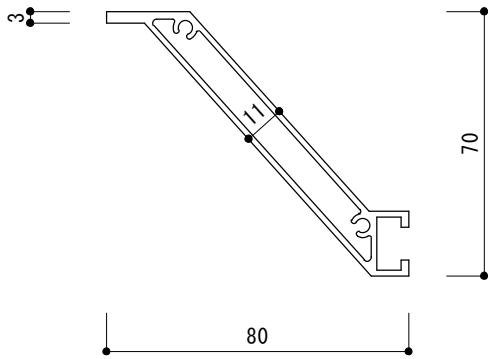

NW-LF6558

使用ボルト	M 8
単位重量	0.8 Kg/m
DIE NO	SYZ-09737

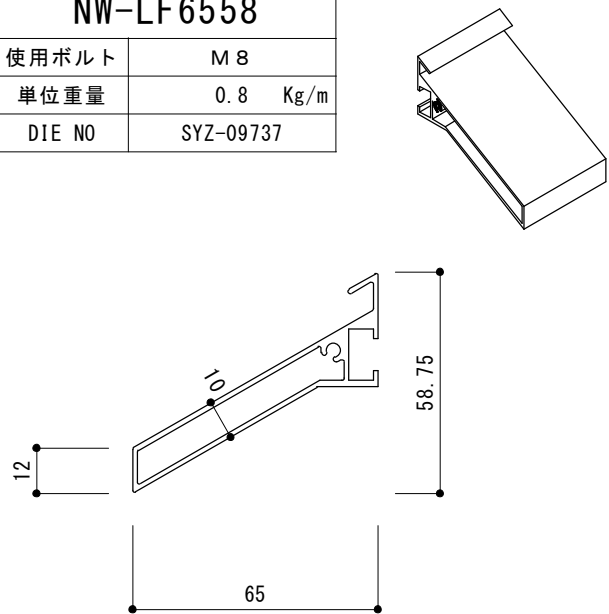

NW-LFR1595

使用ボルト	M 1 0
単位重量	2.289 Kg/m
DIE NO	3SYZ-1673

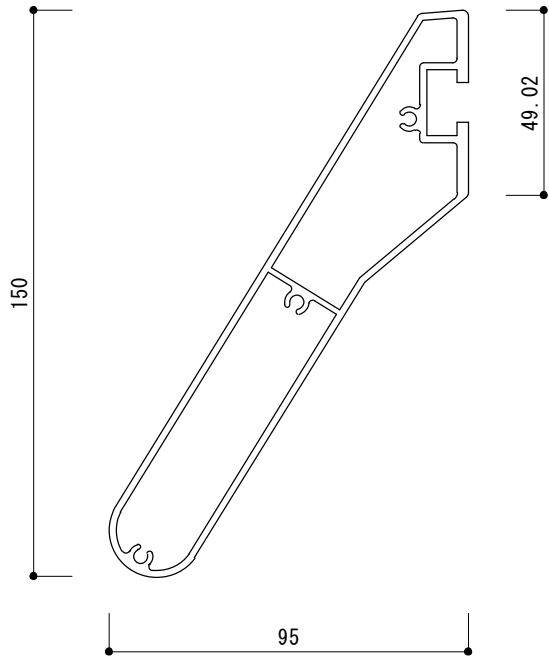
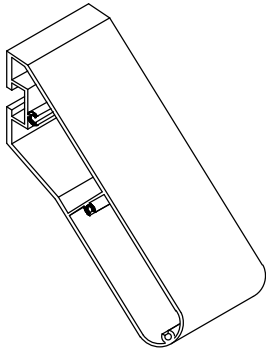

NW-LF1160

使用ボルト	M 8
単位重量	1.273 Kg/m
DIE NO	SYZ-08972

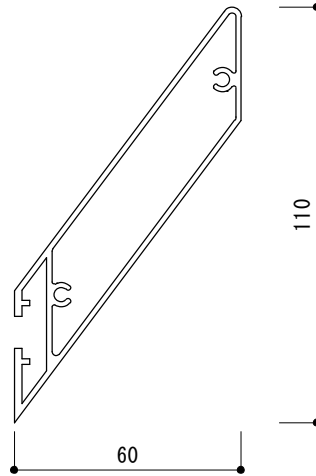
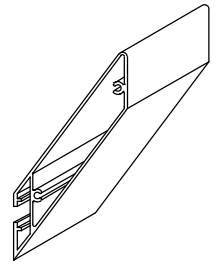

NW-LF1060

使用ボルト	M 8
単位重量	1.061 Kg/m
DIE NO	3SYZ-3572

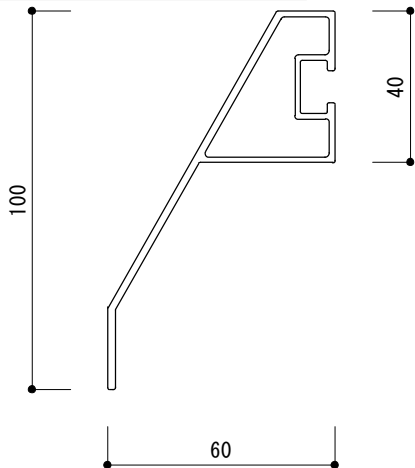
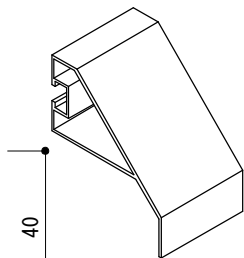

NW-LF8060

使用ボルト	M 8
単位重量	0.810 Kg/m
DIE NO	3SYZ-4021

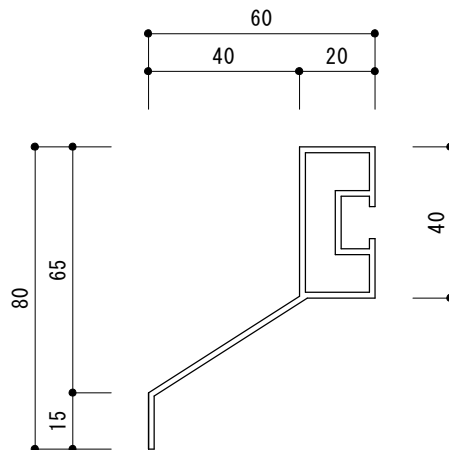
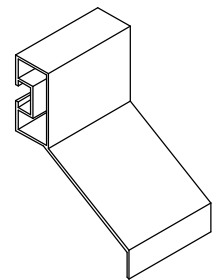

NW-LF6553

使用ボルト	M 8
単位重量	0.7 Kg/m
DIE NO	SYZ-09672

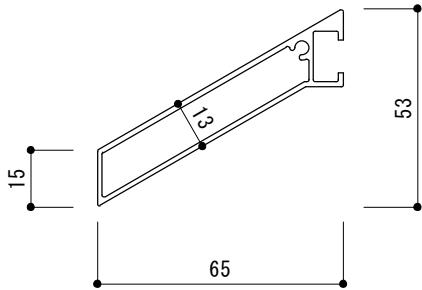
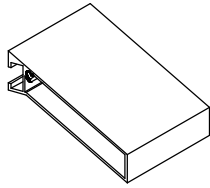

NW-LFR1420

使用ボルト	M 16
単位重量	3.780 Kg/m
DIE NO	3SYZ-0855

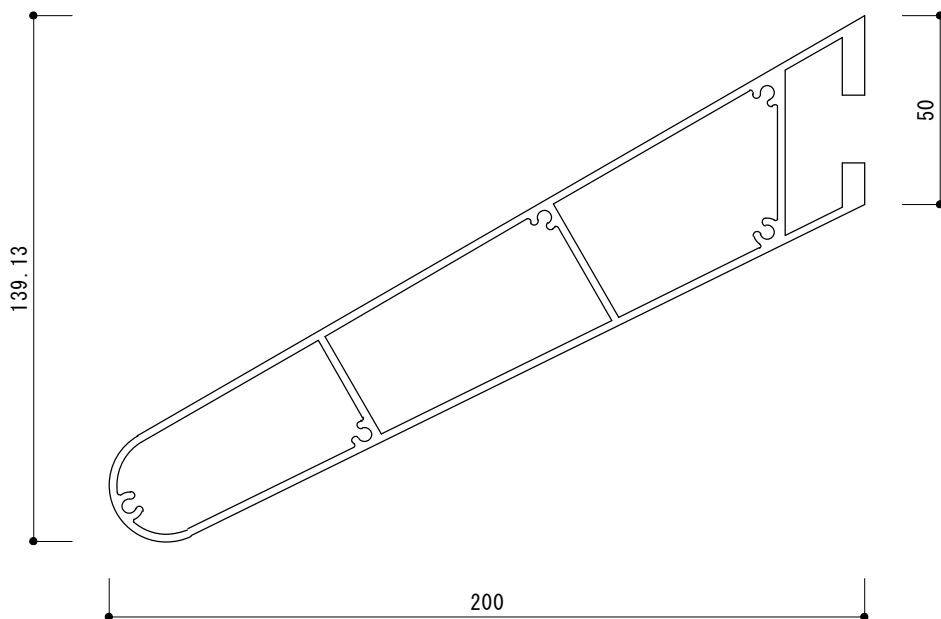
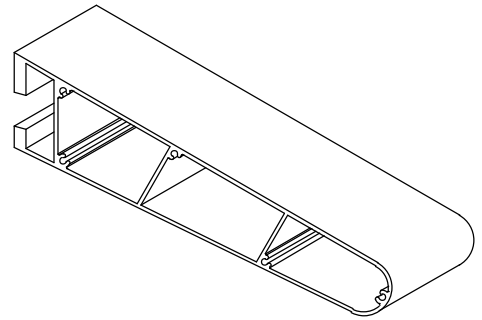

NW-LFR3065

使用ボルト	M 8
単位重量	6.504 Kg/m
DIE NO	1706-2

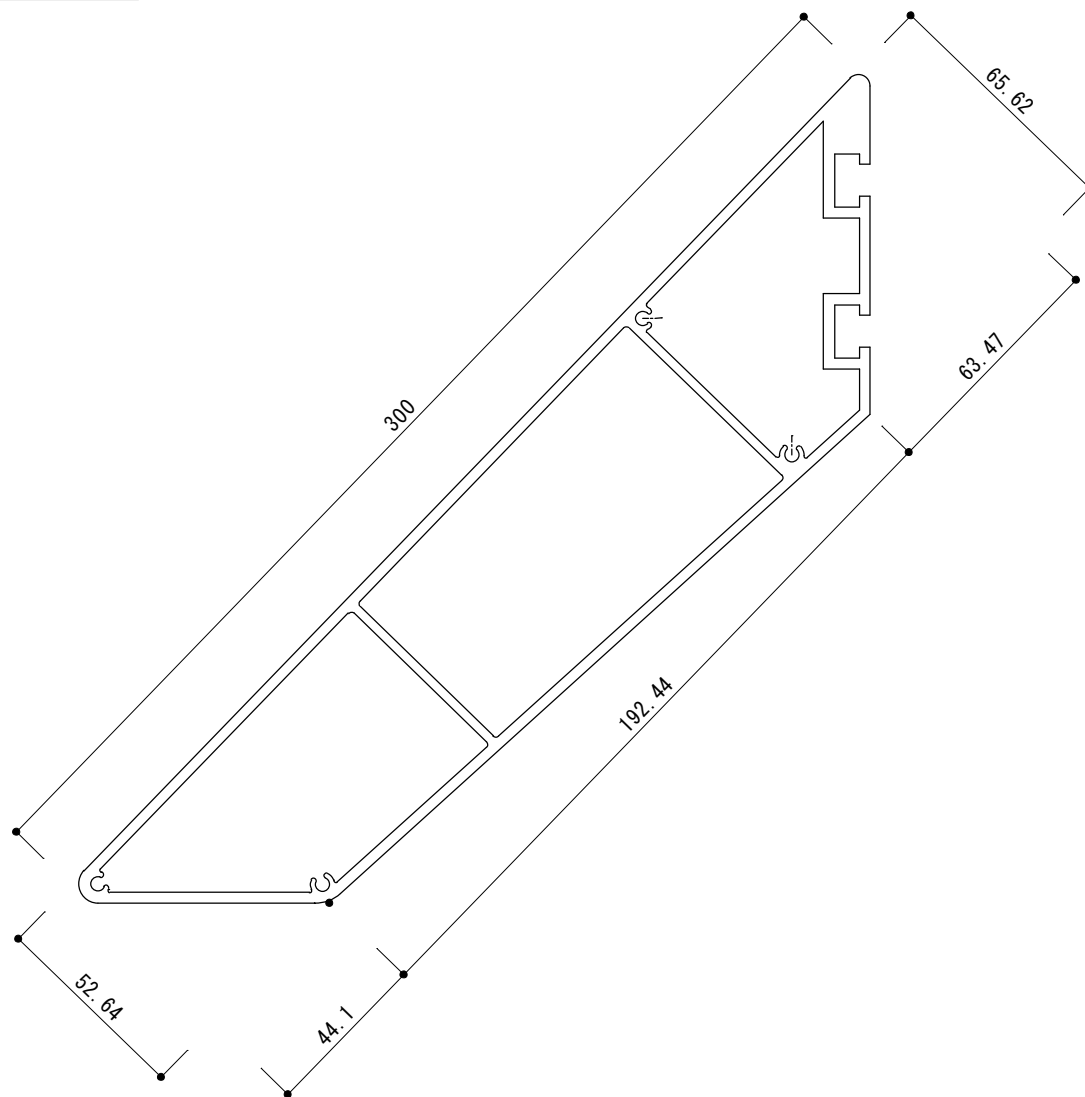

NW-LLS2510

使用ボルト	M 8
単位重量	0.953 Kg/m
DIE NO	SYZ-08935

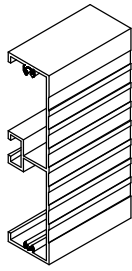
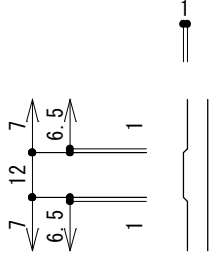
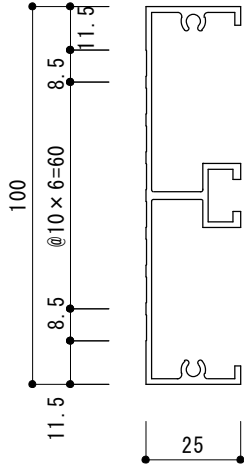

NW-LS2510

使用ボルト	M 8
単位重量	0.919 Kg/m
DIE NO	3SYZ-3073

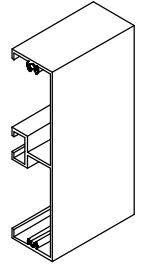
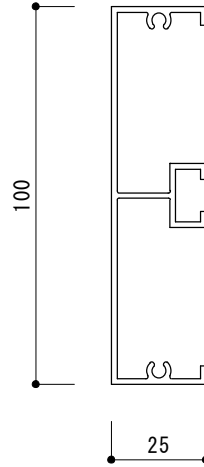

NW-LLS2515

使用ボルト	M 8
単位重量	1.147 Kg/m
DIE NO	SYZ-08936

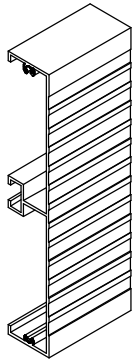
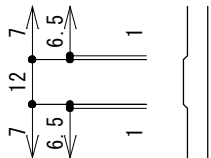
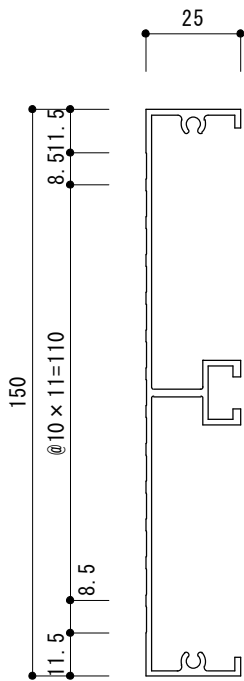

NW-LC75

使用ボルト	M 8
単位重量	0.971 Kg/m
DIE NO	3SYZ-3072

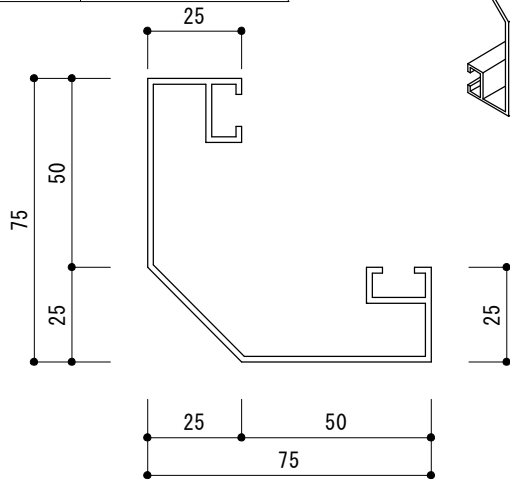
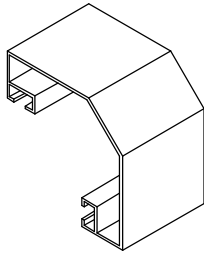

■ アルミスパンドレール ■

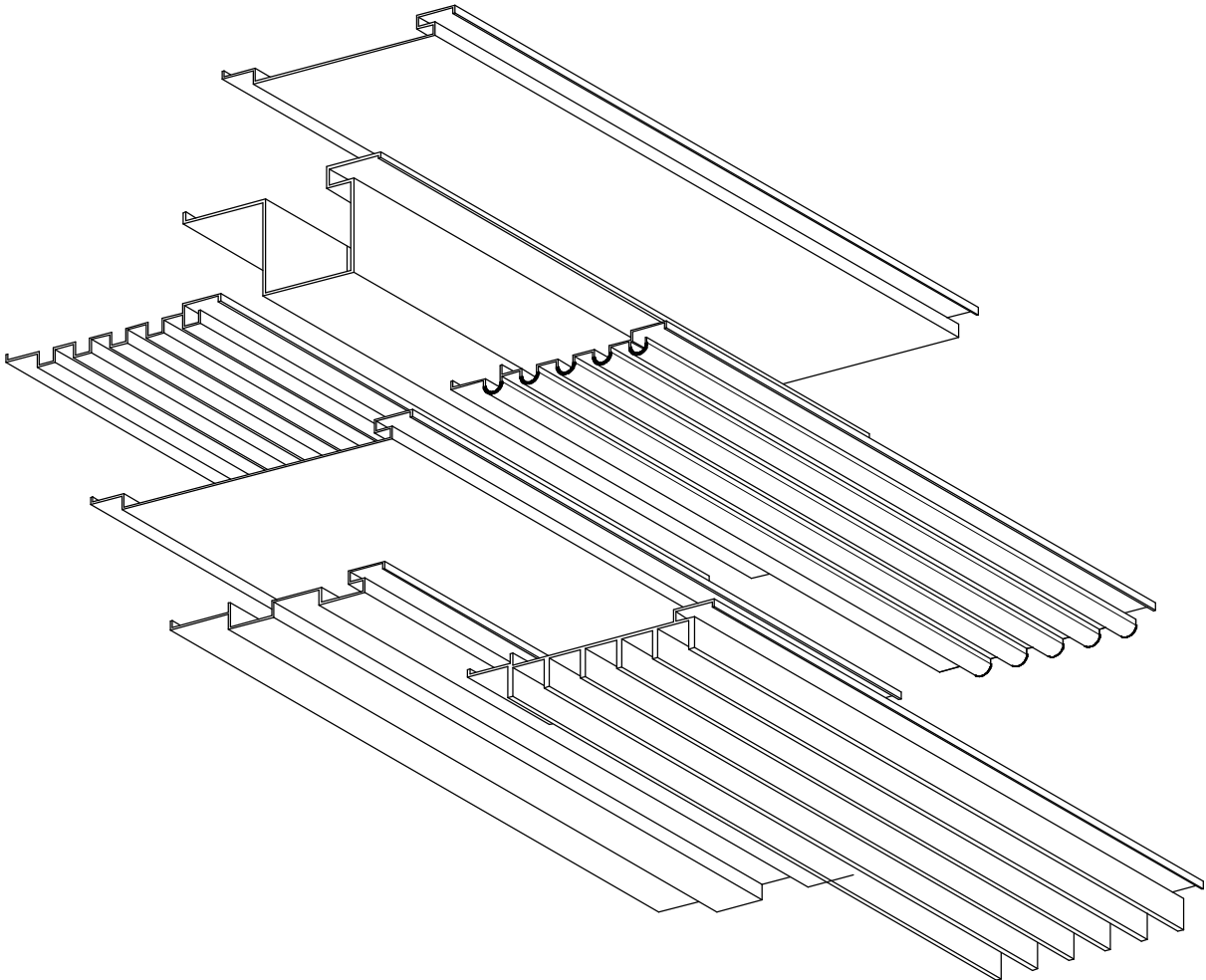

NW-SP1310F

13mm仕様

働き巾	110
単位重量	0.503 Kg/m
DIE NO	3SYZ-1874

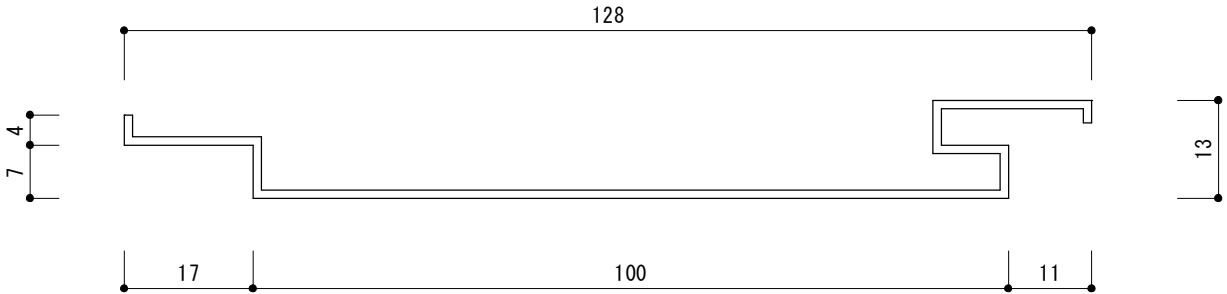
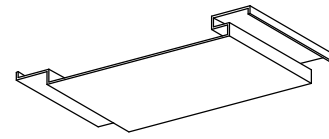

NW-SP1310FC

13mm仕様

働き巾	100
単位重量	0.473 Kg/m
DIE NO	3SYZ-2208

目地無タイプ

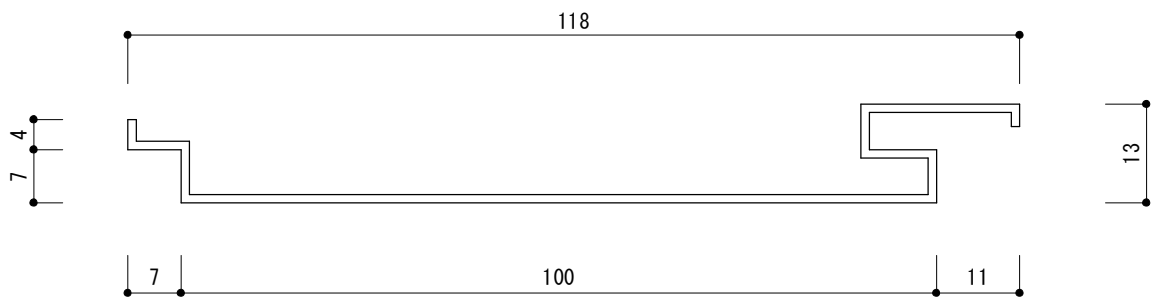
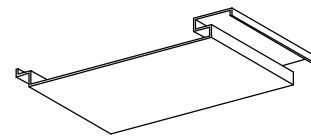

NW-SP1315F

13mm仕様

働き巾	160
単位重量	0.886 Kg/m
DIE NO	3SYZ-2209

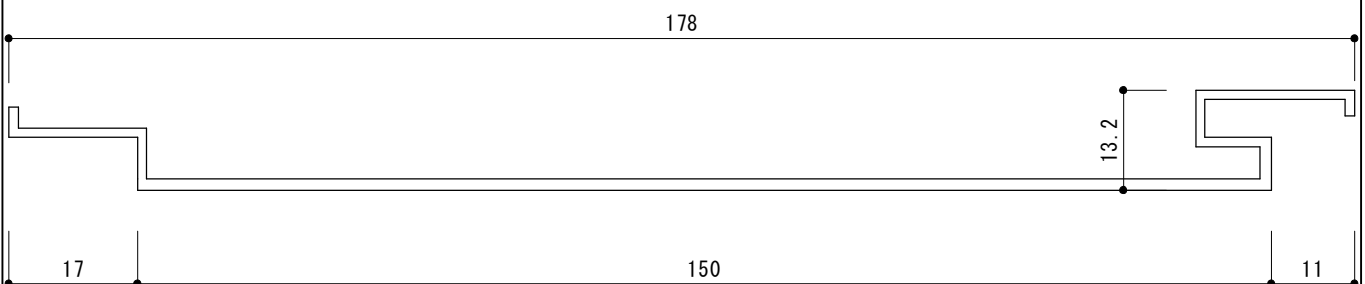
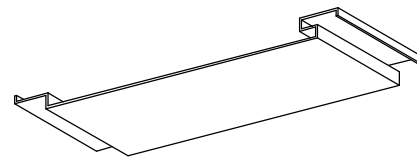

NW-SP1310K

13mm仕様

働き巾	100
単位重量	0.473 Kg/m
DIE NO	3SYZ-2072

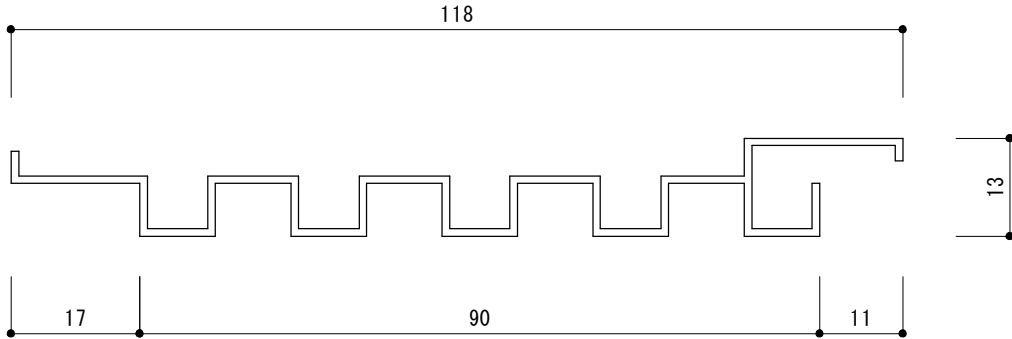
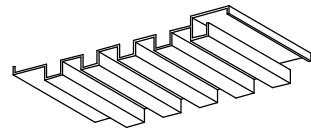

NW-SP13B

DIE NO	3SYZ-1343
--------	-----------

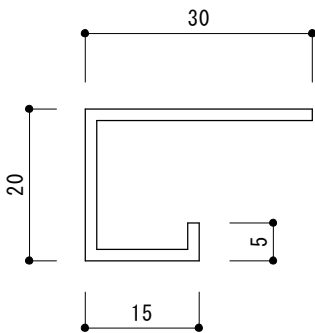

NW-SP13BM

DIE NO	3SYZ-1345
--------	-----------

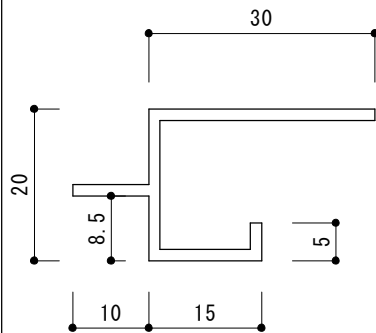

NW-SP13BJ

DIE NO	3SYZ-1344
--------	-----------

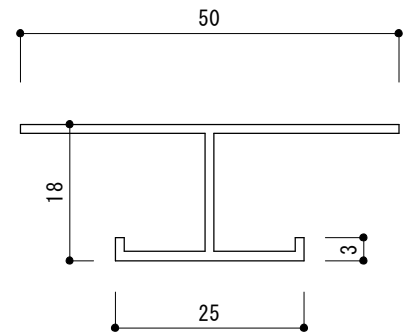

NW-SP1410K

14mm仕様

働き巾	100
単位重量	0.49 Kg/m
DIE NO	3SYZ-1006

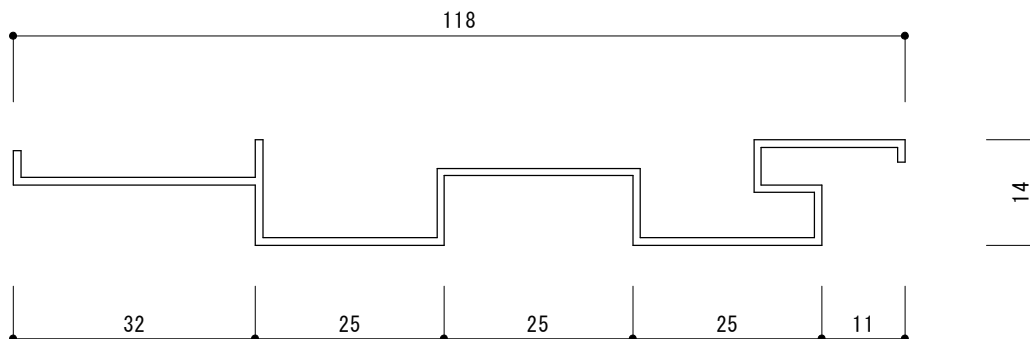
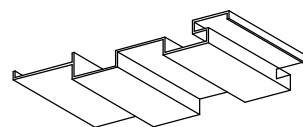

NW-SP14BJ

DIE NO	-(3LB-0199)
--------	-------------

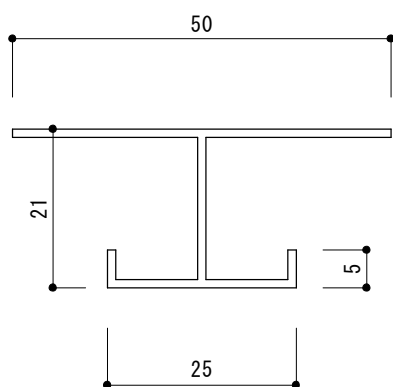

NW-SP2310K

23mm仕様

働き巾	100
単位重量	0.667 Kg/m
DIE NO	3SYZ-1004

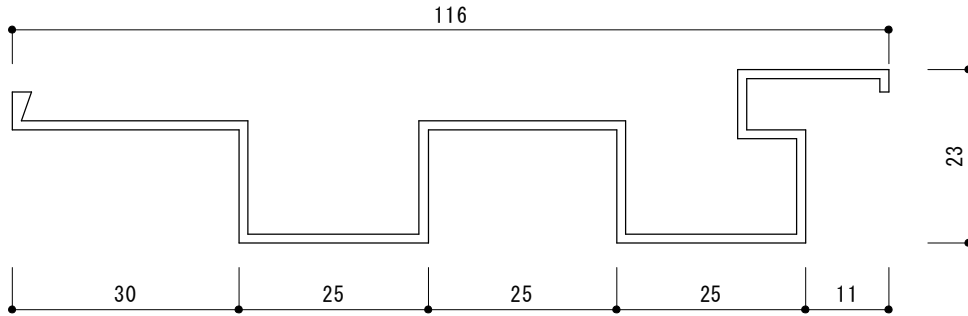
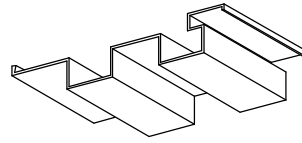

NW-SP23B

DIE NO	3SYZ-1005
--------	-----------

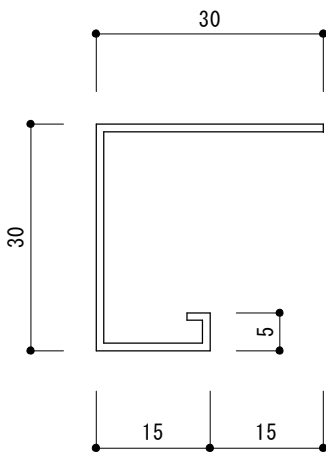

■ アルミ化粧見切り ■

■ パネル部材 ■

■ アルホリック部材 ■

NW-M250C

単位重量	2.82 Kg/m
DIE NO	3SYZ-0672

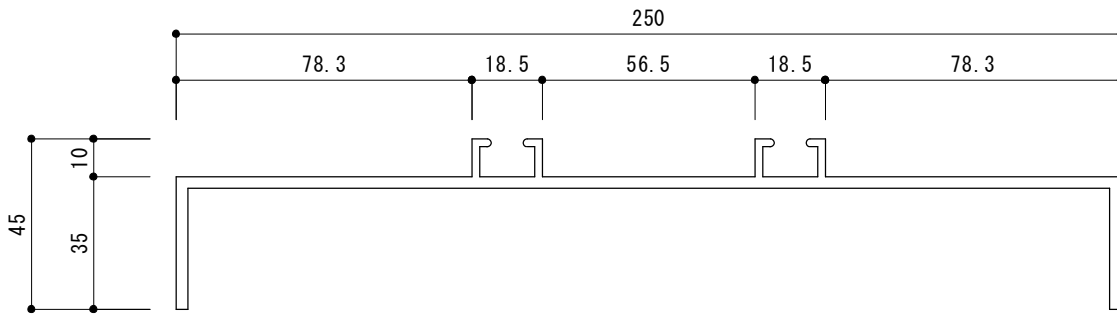

NW-M150C

単位重量	2.7 Kg/m
DIE NO	SYZ-15035

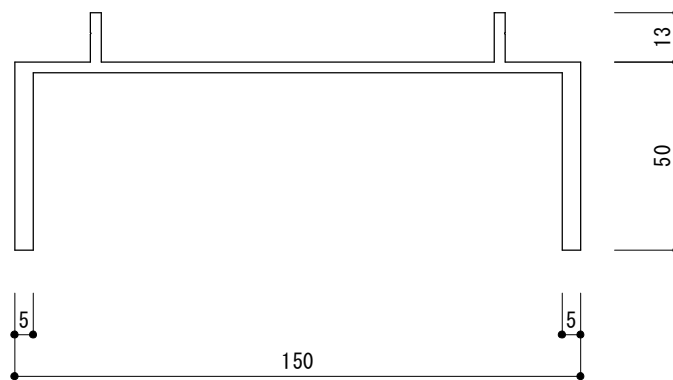

NW-M3767

単位重量	0.889 Kg/m
DIE NO	3SYZ-1168

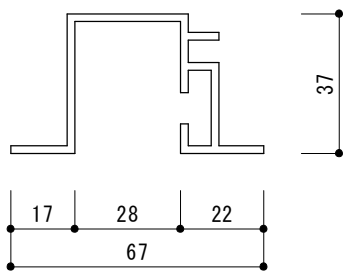

NW-M1010

使用ボルト	M 1 2
単位重量	3.948 Kg/m
DIE NO	1811-72-1

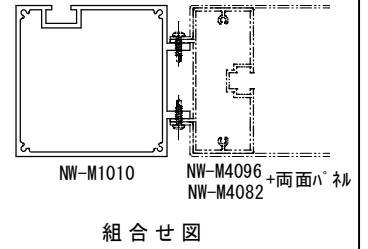
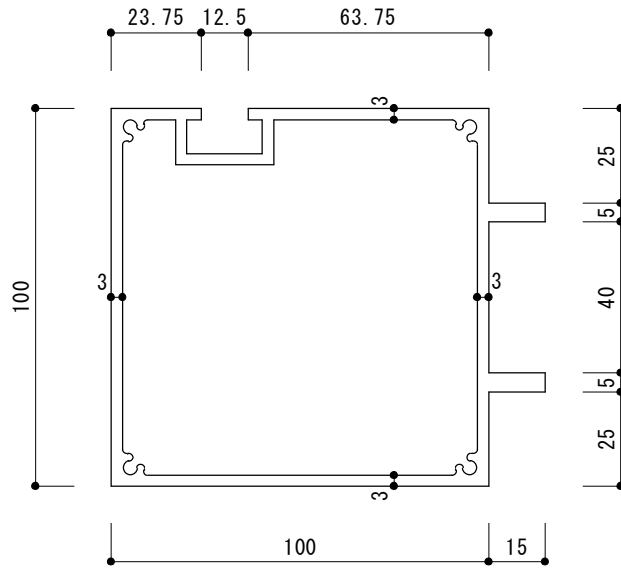

NW-M4096

使用ボルト	M 1 0
単位重量	1.925 Kg/m
DIE NO	1812-14

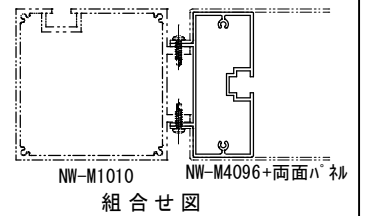
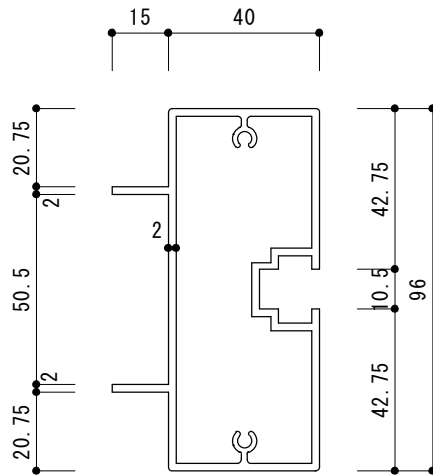

NW-M4082

使用ボルト	M 1 0
単位重量	1.773 Kg/m
DIE NO	1811-72-2

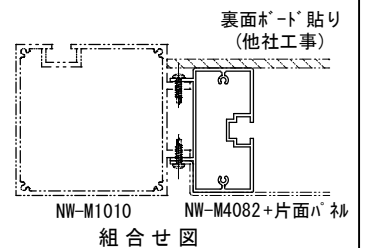
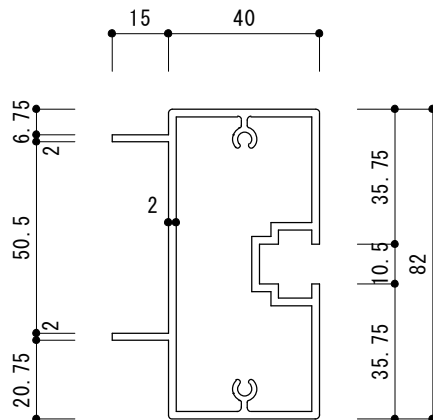

NW-M5014L

単位重量	2.537 Kg/m
DIE NO	ANZ-0163

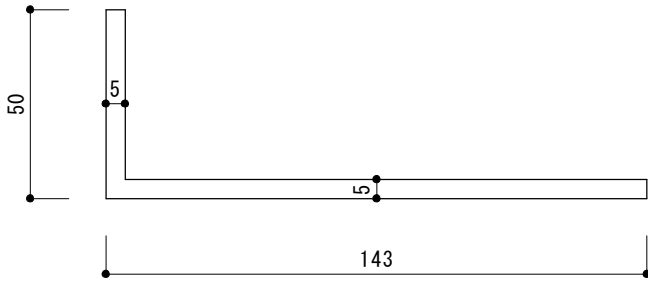

NW-M5012L

単位重量	2.544 Kg/m
DIE NO	ANG-0109

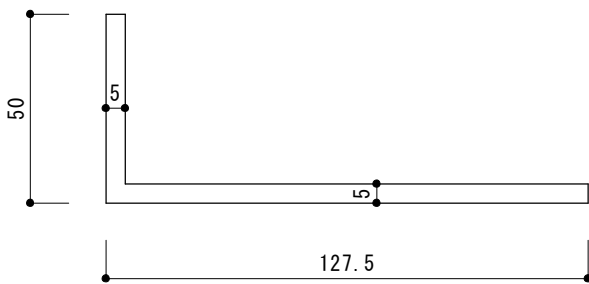

NW-M5050L

単位重量	1.041 Kg/m
DIE NO	1805-82

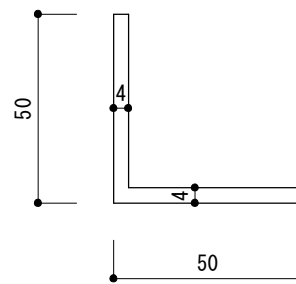

NW-ALP/1		NW-ALP/2	
単位重量	0.511 Kg/m	単位重量	0.252 Kg/m
DIE NO	SYZ-10665	DIE NO	SYZ-10666
NW-ALP/3		NW-ALP/4-1	
単位重量	0.202 Kg/m	単位重量	0.92 Kg/m
DIE NO	SYZ-10740	DIE NO	SYZ-11061
NW-ALP/4-2		NW-ALP/5	
単位重量	0.536 Kg/m	単位重量	0.481 Kg/m
DIE NO	SYZ-11062	DIE NO	SYZ-12080

NW-ALP/6-1

単位重量	0.522 Kg/m
DIE NO	SYZ-11063

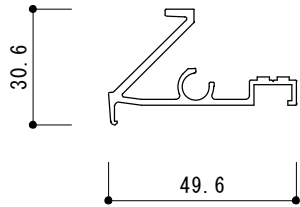
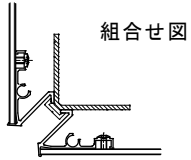

NW-ALP/6-2

単位重量	0.772 Kg/m
DIE NO	SYZ-11064

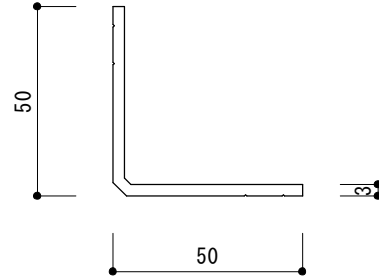
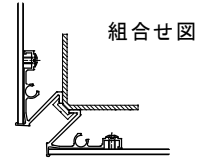

NW-ALP/6-3

単位重量	0.108 Kg/m
DIE NO	SYZ-11065

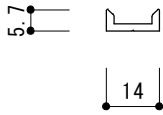
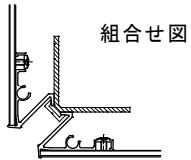



日本ウォール建材株式会社

本社	大阪市天王寺区烏ヶ辻 2 丁目 2 - 8 天王寺福岡ビル 3 階	〒543-0042	TEL (06) 6773-1703 FAX (06) 6773-1704
工場	愛媛県新居浜市多喜浜 6 丁目 1 0 - 1 4	〒792-0893	TEL (0897) 45-4350 FAX (0897) 45-4360

<http://nihonwall.c.ooco.jp/>

- 品質向上のため予告なく仕様を変更する場合がありますのでご了承ください。
- 最新の情報は各営業担当にお尋ねください。